



The solid rubber pipe system for conveying abrasive und corrosive materials

applications in industries

mining – steel works – sand and gravel

cement – pulp and paper

power plants – chemical – and others

at points of strong wear and

for casing entire pipeworks

02 Features and advantages

03 Design criteria

04 Straight rubber pipes GUR, GUR-S, GUR-V

05 Branches GUR-T and GUR-Y

06 Bends GUR-BG and GUR-BG-R

07 Compensating reducers GUR-KR

08 Compensators GUR-K

09 Flanges

10 Mounting accessories

11 Advice and service



02 | Features and advantages of rubber pipe system GUR

The GUR system is our solid rubber pipe system for casing entire pipeworks.

The **straight pipes** GUR, GUR-S and GUR-V hold stiffening elements optionally made of metal or heavy-duty fiber composites. In contrast to hoses, they can simply be laid on a pipe route.

The various **shaped parts** such as bends GUR-BG, branches GUR-T and GUR-Y, reducers GUR-KR and compensators GUR-K are usually not equipped with stiffening elements and thus offer residual flexibility.

Rubber pipes advantageously replace other types of pipes, for example made of rubber-coated steel or plastic.

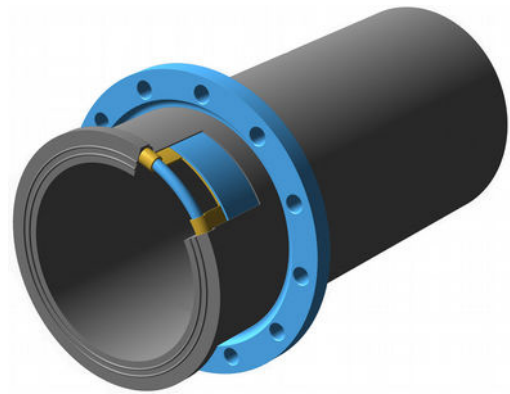

What are advantages of the system GUR ?

1. Rubber pipes allow **very high wear layer thickness** that rubberized lines cannot achieve.
2. In combination with our special rubber compounds, **very long service lives** can often be achieved.
3. GUR is **self-compensating** and does not require any lyre arches or slide bearings. The entire GUR system can be mounted on the simplest of fixed bearings.
4. Due to **flexibility** of molded parts, mounting tolerances or movements of adjacent lines can be compensated.
5. Bends and reducers can be used, for example, to **decouple pipelines from pump vibrations**.
6. Conveying in a rubber pipe generates **less noise** than a comparable steel pipe.
7. Rubber has **low thermal conductivity**, so additional thermal insulation or trace heating can often be dispensed with.
8. The pipe roughness of rubber pipes usually remains technically smooth during operation, so that **lower flow losses** can be expected.
9. Compared to pipes made of steel or plastic, the rubber surface on the inner wall **hardly allows any caking** of the conveyed medium.



With our rubber pipe system, therefore, economically advantageous solutions for difficult transport tasks can be implemented.



03 | Design criteria for rubber pipes



a) pressure conditions

We design our components individually for the pressure conditions in your system. We take the following parameters into account:

nominal pressure	Abbreviated by „PN“ (Pressure Nominal). It is the design pressure of the component and represents the maximum permissible operating pressure.
operating pressure	It is the pressure at which the pipe or pipeline is actually operated. In many cases the operating pressure is below the nominal pressure and can be used for an improved component design.
vacuum	If the pressure in the pipe falls below atmospheric pressure, we speak of a vacuum. The information is given in unit <i>bar absolute</i> or as a <i>percentage</i> , where 100% vacuum is equivalent with 0,00 bar absolute. Vacuum can also occur briefly in pressure lines when pumps are switched off or gate valves are closed.

b) pumped medium

We select a suitable rubber compound for the inner wearing layer ("bore") and the cover of the component. The following criteria are decisive for the selection:

- type of mediums,**
- temperature** of the medium and
- ambient conditions,** especially high temperatures or contact with oil.

We also consider special requirements for the **electrical conductivity** (electrically conductive or insulating) when selecting the rubber quality.

We often use rubber compounds with the following types of rubber:

type of rubber	shortcut	general properties	temperature	used as
chloroprene rubber	CR	Very good UV, ozone and weather resistance, flame retardant.	80 °C	cover
ethylene propylene diene monomer rubber	EPDM	Very good ozone and weather resistance, good resistance to steam and many chemicals. Not oil resistant.	120 °C (aqueous media)	inner bore, cover
nitrile butadiene rubber	NBR	Very good oil and fuel resistance. Not ozone and weather resistant.	80 °C (aqueous media)	Inner bore
natural rubber, styrene-butadiene rubber	NR - SBR	High elasticity, very abrasion-resistant, conditionally oil-resistant, not weather-resistant.	80 °C (aqueous media)	inner bore, cover

04 | Straight rubber pipes **GUR, GUR-S, GUR-V**

Standard layout **GUR**

The rubber pipe GUR offers a high level of stiffness and is particularly **suitable for laying pipelines**. Free laying in **uneven terrain** or floating on **pontoons** is also possible.

The possible wearing layer thickness depends on the nominal size. Depending on the application, rubber compounds tailored to abrasive or corrosive media are used.



Technical data

ND [mm]	maximum strength of wear layer for PN 10 / 6 [ca. mm]	nominal pressure PN up to [bar]	length		width between supports guideline [m]	weight per m guideline [ca. kg/m]	outer diameter guideline [ca. mm]	fittings	
			from ¹ [m]	to [m]				loose flange type	fixed fl. type
40	4	16 > =25 on request	0,5	12	3	3	60	FL,FLR,SL	FR,SF
50	4		0,5	12		4	70	FL,FLR,SL	FR,SF
65	6		0,5	12		5	90	FL,FLR,SL	FR,SF
80	6		0,5	12		7	105	FL,FLR,SL	FR,SF
100	6		0,5	12		11	130	FL,FLR,SL	FR,SF
125	7		0,5	12		14	155	FL,FLR,SL	FR,SF
150	7		0,5	12		20	180	FL,FLR,SL	FR,SF
200	10		0,5	12		30	240	FL,FLR,SL	FR,SF
250	10		0,5	12		35	290	FL,FLR,SL	FR,SF
300	10		16	0,5		12	45	340	FL,FLR,SL
350	12	16	0,5	12	55	400	FL,FLR	FR	
400	12	16	0,5	12	65	450	FL,FLR	FR	
500	12	16	0,5	12	90	550	FL,FLR	FR	
600	12	16	0,5	6	110	650	FL,FLR	FR	
700	16	10	0,5	6	140	760	FL,FLR	FR	
800	16	10	0,5	6	160	860	FL,FLR	FR	
900	16	6	0,5	6	180	960	FL,FLR		
1000	20	6	0,5	6	220	1070	FL,FLR		
1200	24	6	0,5	6	280	1280	FL,FLR		

¹ Shorter pipes are provided as GUR-K (without stiffening layer).

Other nominal diameters, nominal pressures and lengths are available on request.

Wear-optimized: **GUR-S**

For heavy abrasive loads, we offer rubber pipes GUR-S with a **thicker wear layer**. This type of construction is used, for example, in gravel and sand conveyance.

In order to significantly increase wear layer thickness also in the flange areas, all GUR parts can be equipped with **larger flanges** than provided in the standard. This design increases the durability of the pipes additionally.



Vacuum-optimized: **GUR-V**

The GUR-V design is suitable for suction and pressure applications likewise.

05 | Branches GUR-T and GUR-Y

Junction components are required for merging or splitting conveying flows. Outlets in small nominal widths are also required in pipelines for cleaning or for connecting measuring devices. With **T-pieces GUR-T** and **Y-pieces GUR-Y** the rubber pipe system covers almost all requirements. Compared to steel or plastic pipes, only larger minimum lengths (m , n , L_2 in the sectional view) have to be observed.

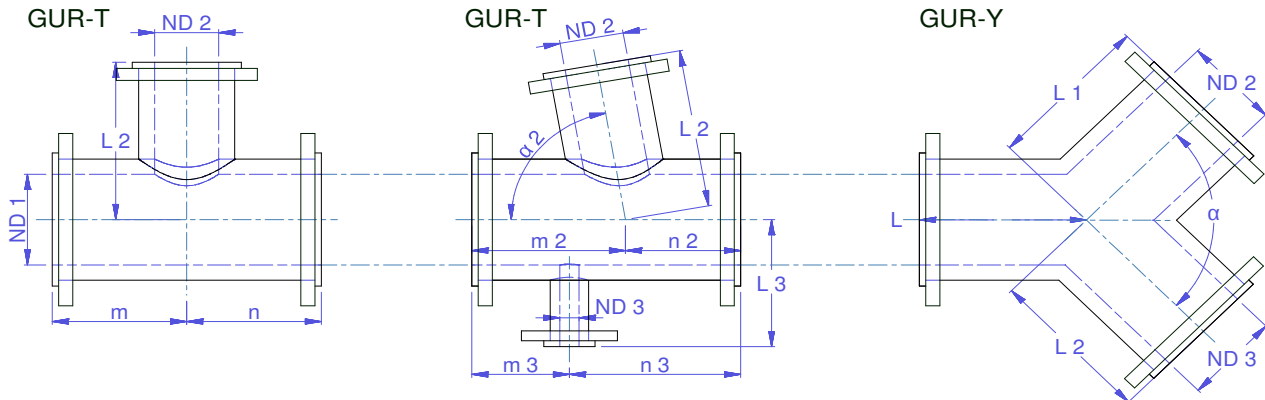

Several outlets from a main pipe can be combined in one component (see middle sectional drawing). The base pipe can also have the same length and stiffness as a straight rubber pipe GUR. This reduces the number of parts and allows **cost-effective solutions**.

Dimensions

GUR-T			GUR-Y				GUR-T, -Y				
ND ₁	ND ₂	α	α=90°	α=30°	α=45°	α=60°	NW	α=60°	α=90°	α=120°	connections
[mm]	[mm]	[°]	$m_{min}=L_{min}$ $= n_{min}$	n_{min}	$m_{min}=L_{min}$ $= 0,75 \times m_{min}$	m_{min}	[mm]	m_{min}	m_{min}	m_{min}	
40	25 <= NW2 <= NW1	15 <= α <= 90	200	694	471	359	40	361	246	187	loose flanges (types FL, FLR) fixed flanges (type FR)
50			200	722	488	371	50	371	252	191	
65			200	760	513	388	65	388	262	197	
80			220	790	533	403	80	403	271	203	
100			240	827	557	421	100	421	281	209	
125			270	885	595	449	125	449	298	220	
150			300	950	637	479	150	479	316	230	
200			340	1055	706	528	200	528	345	248	
250			380	1159	774	578	250	578	380	265	
300			420	1253	834	621	300	621	410	280	
350			450	--	907	673	350	675	440	299	
400			480	--	--	725	400	731	470	320	
500	540	--	--	--	500	828	530	355			
600	590	--	--	--	600	929	600	390			

The data given are guidelines. We would be happy to check your requirements for feasibility.



06 | Rubber pipe bends **GUR-BG** und **GUR-BG-R**

Rubber pipe bends differ in construction from straight rubber pipes in that they do not have a stiffening layer. The resulting **flexibility** is useful when building pipelines, as they compensate for small differences in length from straight sections. immuG's special production process for rubber pipe bends allows both the bending **radius and angle to be continuously adjusted**. Thus, existing complex pipelines can be replaced by rubber pipes.



Rubber pipe bends in standard design are not vacuum-proof and can temporarily contract. Occasional negative pressure does not affect their service life. Rubber pipe bends, which are constantly under vacuum, are equipped with reinforcements.

Rubber pipe bends with leg elongations offer the user two advantages: An extension on the inlet side ensures a **"softer" flow deflection** and extends service life in face of highly abrasive loads. Second, short compensating or fitting pieces are unnecessary. The designs of a reduction (or expansion) bend GUR-BG-R also **reduces the number of components** in pipeline construction.

For conveying **extremely abrasive** suspensions, we offer special constructions with a reinforced **wear layer up to 100 mm** in the outer curve. On request, we also equip them with robust fixed flanges type FR.

Technical data

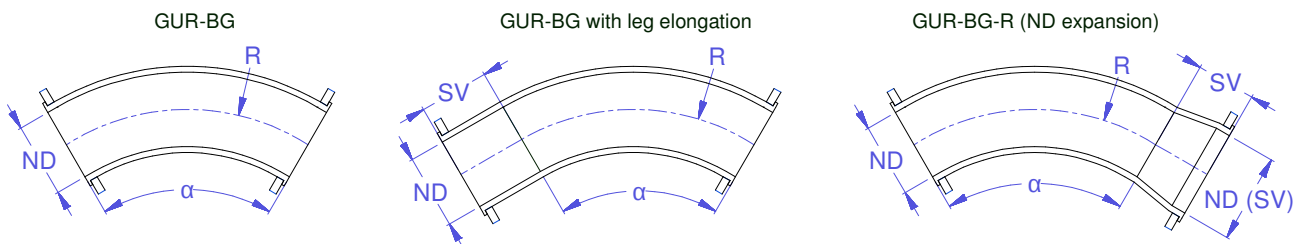

ND [mm]	standard bends radius R				lower limit R _{min} α=90° [mm]	R _{max} for α=90° [mm]	upper limits		connections	
	α=90° [mm]	60° [mm]	45° [mm]	30° [mm]			ND(SV) _{max} [mm]	SV _{max} for R/NW=3 [mm]	loose flange type	fixed flange type
40	200	300	400	600	200	1900	65	100	FL,FLR	FR
50	200	300	400	600	200		80	150	FL,FLR	FR
65	225	340	450	600	225		100	200	FL,FLR	FR
80	260	375	480	600	260		125	250	FL,FLR	FR
100	340	375	500	600	340		150	300	FL,FLR	FR
125	375	500	600		375		200	350	FL,FLR	FR
150	450	500	600		425		200	400	FL,FLR	FR
200	600	700			540		250	500	FL,FLR	FR
250	750	800			625		300	550	FL,FLR	FR
300	800	900			700		350	550	FL,FLR	FR
350	900	1050			800	400	550	FL,FLR	FR	
400	1100	1200			900	--	550	FL,FLR	FR	
500	1300	1450			1125	--	600	FL,FLR	FR	
600	1600	1650	1750		1375	1825	--	--	FL,FLR	FR
700	1700	1750	1800	2000	1600		--	--	FL,FLR	FR
800	1825	1900	2000	2250	1750		--	--	FL,FLR	FR
900	1825	2100	2250	2500	1800		--	--	FL,FLR	
1000	1825	2350	2450	2800	1825		--	--	FL,FLR	

The data given are guidelines. We would be happy to check your requirements for feasibility.

06 | Rubber pipe bends **GUR-BG** and **GUR-BG-R**



vacuum-proof bend with steel rings



bends with elongated legs



bend with diameter expansion



reinforced wear layer
for extremely abrasive applications



07 | Compensating reducers GUR-KR

Compensating reducers GUR-KR combine the functions of a "rigid" reducer with those of a "resilient" compensator. The construction principle is also applied to compensators GUR-K with constant nominal width (see sheet 08).

Function as a reducer

A reduction in nominal diameter is often necessary in the layout of pipelines. At branches and especially at pumps, reductions are required to adapt the flow velocities. These components are subject to increased wear, as the change in nominal diameter is accompanied by turbulence and cavitation. Behind pumps, they are additionally stressed by rotating swirls of the product flow. Reductions made of conventional materials often achieve unsatisfactory service lives.

- Thanks to the solid rubber construction, GUR-KR achieve a significantly **longer service life** than components made of metal or plastic.

Function as a compensator

Compensators in pipelines dampen vibrations and compensate for movements between parts of the pipeline as well as pressure fluctuations.

- GUR-KR have a smooth inner bore without a bulging hollow chamber and thus allow an **optimal flow**.
- The special textile reinforcement allows **movements in axial, lateral and radial directions** and absorbs pressure forces from the pipe.
- The textile-reinforced rubber body acts as a strongly damped spring and ensures **vibration-decoupling** between line parts or aggregates.
- In contrast to classic expansion joints, GUR-KR do not exercise any force on counter flanges of pumps or other sensitive units. This is ensured by the special textile construction that keeps GUR-KR **stable in length** under working pressure and absorbs pressure fluctuations solely through changes in diameter.



Dimensions

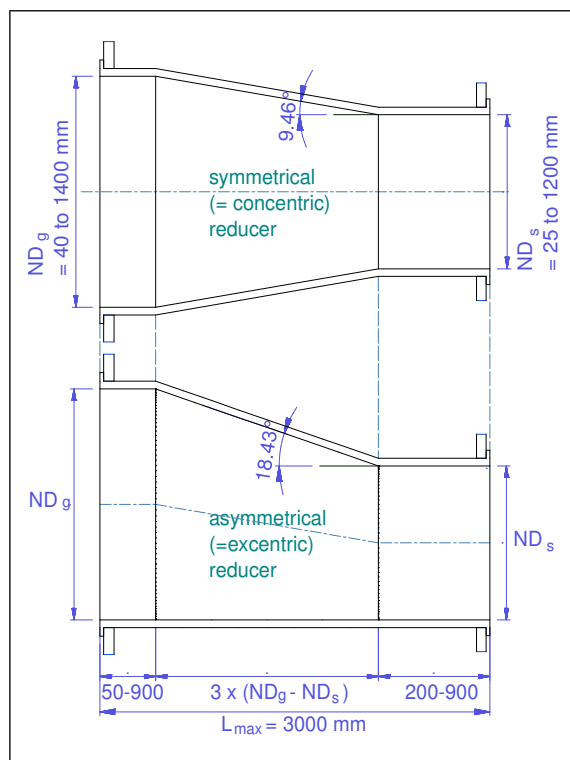

Reducers can be equipped with extra outlets in diameters up to 200 mm.

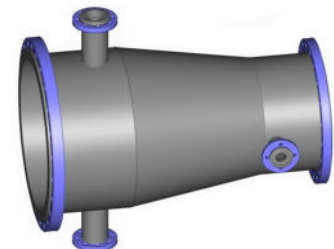

Advantages of compensating reducers in plant construction

- GUR-KR **replace** combinations of a rigid reducer and a bellows expansion joint at pumps with large volume flows of abrasive and corrosive fluids.
- Compared to bellows expansion joints, they achieve **longer service life** and allow **flow speeds** of up to 10 m / s.
- The **asymmetrical** design offers the same compensating behaviour without any torsional or bending torques.
- Any required **measuring or drainage nozzles** can be integrated in the cylindrical areas.
- We design each part **individually** and take your conveying conditions, connecting dimensions and spatial restrictions into account.

08 | Compensators **GUR-K**

Compensators in pipelines dampen vibrations and equalize movements between pipe parts as well as pressure fluctuations.

Straight compensators GUR-K correspond to compensating reducers GUR-KR (see sheet 07) in terms of construction and behaviour - with the difference that the pipe diameter is constant.

Standard design

The inner bore of the standard design is smooth without a bulging hollow chamber, so that these advantages apply:

- GUR-K allow an **optimal flow**.
- The special textile reinforcement allows **movements in axial, lateral and radial directions** and absorbs pressure forces from the pipe.
- The textile-reinforced rubber body acts as a strongly damped spring and ensures **vibration-decoupling** between line parts or aggregates.
- In contrast to bellows expansion joints and other types of expansion joints, GUR-K do not exercise any force on counter flanges of pumps or other sensitive units. This is ensured by the special textile construction that keeps GUR-K **stable in length** under working pressure and absorbs pressure fluctuations solely through changes in diameter.



Compressible design	Dimensions
<p>To compensate for the expansion of straight line sections, we equip GUR-K with one or more compressible hollow shafts, see product example below.</p> <p>At higher pressures, we recommend to limit elongation by bracing up the flanges, by that keeping forces off the connecting flanges.</p>	<ul style="list-style-type: none"> • Nominal diameter (ND): 25 - 1200 mm • Minimum lengths: ND-dependent, at least 200 mm • Measuring or drainage nozzles up to NW 200 mm can be integrated. • We design each component individually and can take your conveying conditions, connection dimensions and spatial restrictions into account.

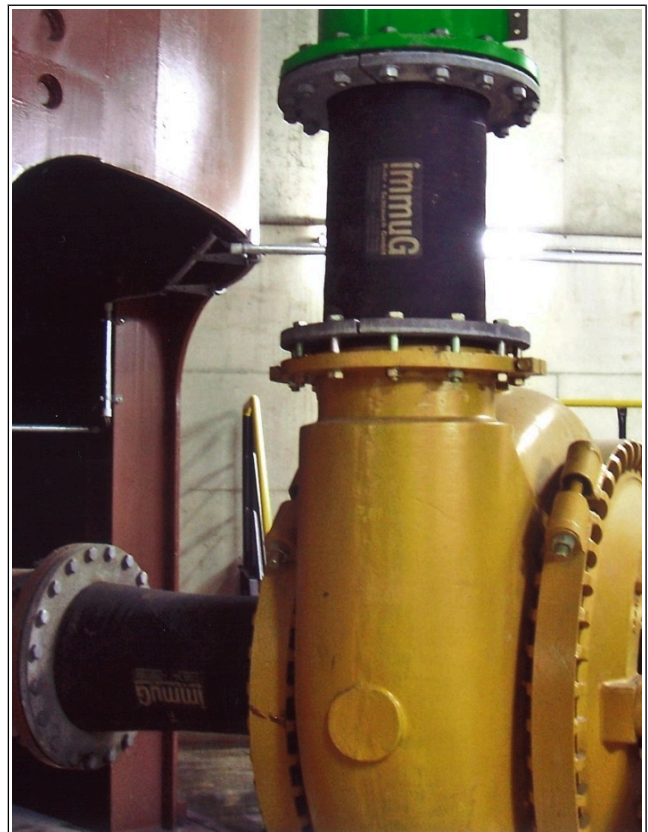

09 | Flanges

Loose flanges FL und FLR

Loose flanges can be used universally and are **easy to install** thanks to the free rotation of the flange. The characteristic element of the construction is the steel ring, which is anchored in the textile reinforcement and lies form-fit against the flange. It guarantees backlash-free transmission of forces between pipe and flange connection.



The **FL** design has the **lowest weight** among ImmuG's flange designs. A FL flange connection achieves optimum sealing properties when the sealing surface is compressed by app. 20%. As an mounting aid, we optionally offer distance bushers, see mounting accessories, see sheet 10.

The **FLR** type is a variant of the FL with an additional metal plate in the sealing surface, which increases **pressure resistance**. This design combines the advantages of a flexible loose flange system and a robust fixed flange system. FLR flanges are particularly suitable for connecting rubber pipes with steel oder plastic pipes.

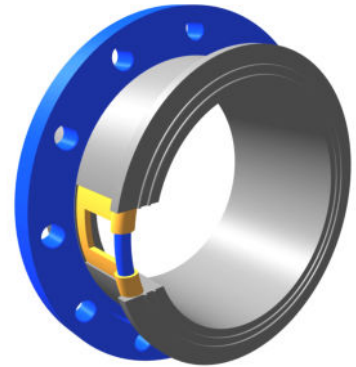

Center-sealing surfaces for loose flanges (ZF A and B)

When pumping highly abrasive suspensions, pipe transitions must be installed without offset in order to prevent turbulences and early wear. The positively and negatively shaped center-sealing surfaces facilitate the **flush assembly** of pipelines. They are available for nominal diameters from 80 to 300.

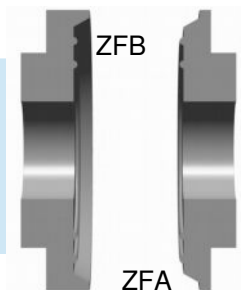

Fixed flange FR

The large sealing surface made of wear layer rubber and metal discs makes the fixed flange insensitive to tilting during assembly and "squeezing" of the sealing surface. The FR flange is therefore particularly suitable for **mounting under rough or cramped conditions**.

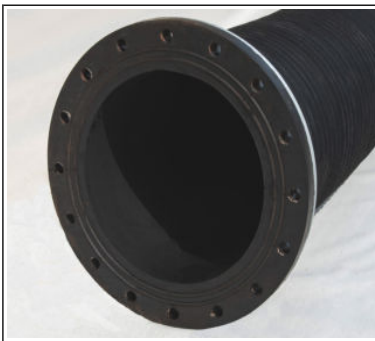

Another advantage for very abrasive applications is the **stronger wear layer in the flange area**, compared to loose flanges. In this design, the textile reinforcements are fixed flat between metal discs in the sealing surface and direct forces from the pipe into the flange.

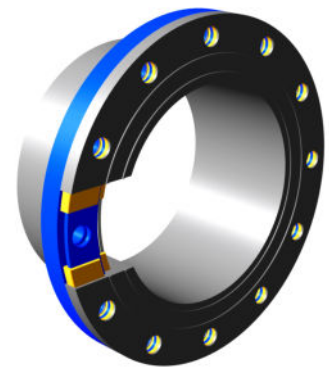

Nozzle with loose flange (SL) or fixed flange (SF)



In pipes with nozzle flanges, a steel nozzle is placed on the inner tubing. The textile reinforcements are anchored on the outside of the socket. This construction is suitable for **extreme strain from longitudinal or side forces**.

Nozzle flanges are possible up to a nominal size of 300. Behind the socket's collar lies either a loose or a fixed flange.

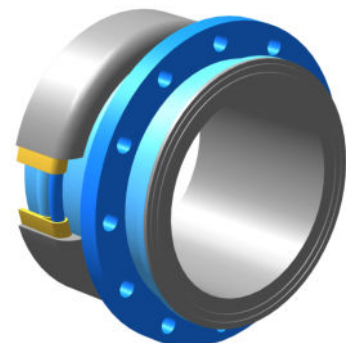

Nozzle with fixed flange SF

Nozzle with loose flange SL

10 | Mounting accessories

Distance bushers for screwing loose flanges

All flange constructions from immuG are screwed pressure-tight without additional sealing inserts. With loose flanges (types FL and FLR), the optimum sealing effect is achieved at approx. **20% compression** of the sealing surfaces. The torques required for this are well below those usual for steel flanges. Tightening the screws stronger would compress the rubber too much and may reduce tightness over time irreversibly.

For safe and yet quick assembly, we offer **distance bushers** in the appropriate lengths, which are attached to the screws between the flanges. The flanges can be screwed until the sleeves are stuck between them. We recommend the use of distance bushers especially for the assembly of entire pipelines.

Flange holders GUR-A for mounting

The low weight of rubber pipe components and their self-compensating behaviour allow mounting with simple fixed bearings.

Our flange holders GUR-A are **tailored to the rubber pipe system**. Also for non-stiffened components (bends, branches, reducers, compensators) and inclined positions they offer firm support without pressure on the rubber body. By fixing the flanges, the rubber body is also relieved from their weight. All GUR-A are attached with 2 screws of the pitch circle to the outside of the flange.

We offer flange holders in 2 versions:

- **"Plate"**: For pipes running on top of a steel construction, 300 mm long plates are suitable for supporting flanges from steel beams below.
- **"Long nut"** : For a suspension from above, these flange holders end with a long nut M16. The connection to the steel structure can be established by a threaded rod - in the case of inclined lines with an elbow connector in between.

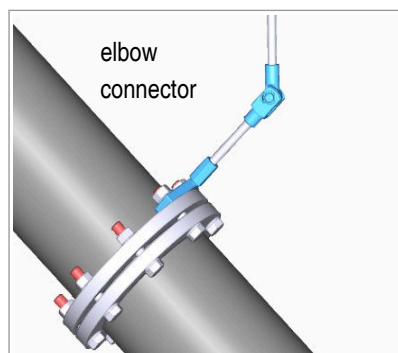
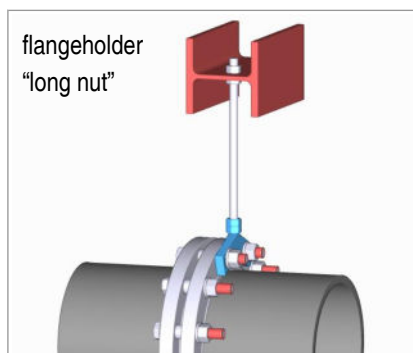
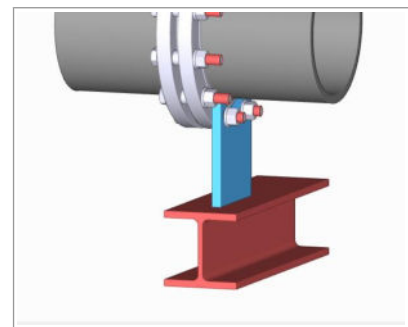
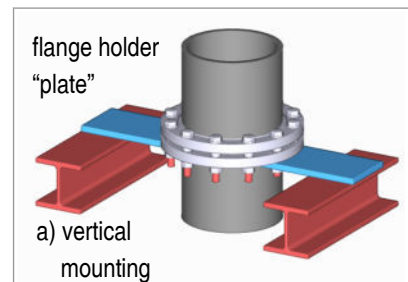
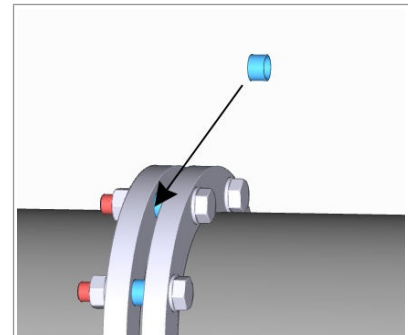

Clamps

Straight, horizontally laid rubber pipes can be mounted with the prescribed span (see sheet 04 *Straight rubber pipes*) in fixed bearings - like steel pipes. In addition to flange holders, clamps with a sufficiently large inner diameter can also be used. Within the span, rubber pipes remain rigid thanks to the built-in stiffening elements.

On request, we will readily supply you with suitable clamps.

11 | Advice and Service

Advice

We design all GUR components according to your requirements and manufacture them as individual parts. **Individual advice is a standard** for us. We take into account essential parameters of pressure-resistant design and of rubber selection, see sheet 03.

Our **field service** will be happy to visit you on site to get to know your system, examine problems and design a suitable solution built with rubber components.

We regularly develop new solutions tailored to specific applications in **cooperation with customers or suppliers**. In doing so, we rely on the experience and knowledge of our employees in sales, engineering and production.

Service

We offer further construction services:

- 3D survey with total station,
- pipeline construction based on 3D survey, isometrics or 2D drawings.

On request we offer as additional services

- component and pipeline drawings,
- certificates according to EN 10204, and carry out
- water pressure or vacuum tests.

Especially for larger projects we offer

- assembly supervision and
- regular pipe inspections.



pipe inspection



3D survey with total station

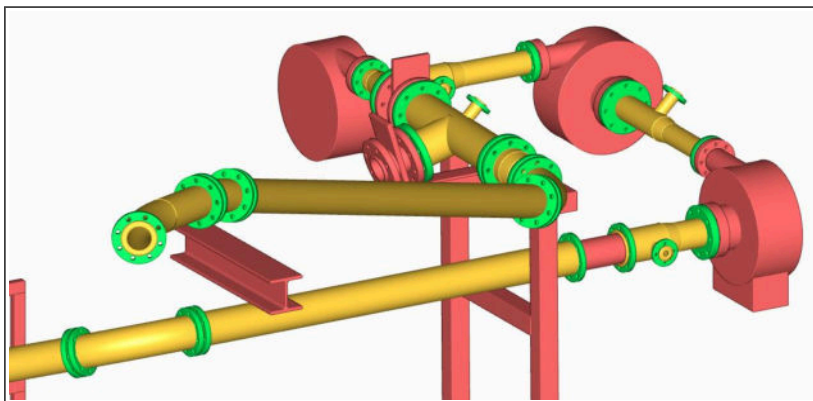

3D construction

pressure test

